



Heavy-Duty Conveyor Broom CB-100



04/19/17

ENGINE
Tier 4i, Kubota® 3.8L 99 hp (75 kW) @ 2,600 rpm
OPERATING WEIGHT
23,000 lbs (10,432 kg)



SAVE TIME & MONEY WITH A PATENTED CLEAN SWEEP SYSTEM FOR FIRST PASS CLEAN-UP

Sweep & Load

The Roadtec CB-100 is a mobile, self-propelled machine designed for sweeping and loading material. Designed with a patented clean sweep system for first pass cleanup, the CB-100 can be used for asphalt milling, snow removal and construction site sweeping. The Roadtec CB-100 Conveyor boom is constructed to be solid, dependable, and durable with a unique combination conveyor and sweeping system components.

Simple Operation

Crew members control operations from a pressurized, dust-free, climate controlled and ROPS certified Cabin. Plush seats, sliding seat options windshield wipers and fingertip control panels provide maximum comfort and optimized visibility.

Save Time & Money

The robust clean sweep system is powered by a low-emissions, Kubota® 3.8L 99 hp (74 kw) engine. The hydrostatic transmission delivers smooth control acceleration for all speed ranges. Oil bath sealed brakes come standard on the machine to increase the wear life and decrease operating costs.

Exclusive Flow System Design

Bushes rotated at 150 RPMs with adjustable, free-floating designs that enable brushes to reach every crevice. Front mounted rakes comb through material to separate and remove large debris. Strike-off blades cut material heights to manageable levels. Specially designed, dual moldboards direct material to center, preventing end gate material loss. Front discharge, endless-cleated, 48" (1219 mm) conveyors transfer material away from the work zone, eliminating the expense of vacuum trucks.

Built to Last

Heavy-duty frames and axles ensure the CB-100 is reliable and dependable. The Roadtec CB-100 is the only conveyor broom of its kind, providing profitability through durability, easy control and a clean sweep.



SPECIFICATIONS

ENGINE

- Tier 4i, Kubota® 3.8L 99 hp (74 kW) @ 2,600 rpm

WEIGHT

- 23,000 lbs (10,432 kg)

ELECTRICAL SYSTEM

- 110 amp sealed alternator
- 12v starting system
- Heavy-duty 16 gauge wiring
- Sealed A/C clutch

PROPEL SYSTEM

- Closed loop hydraulic circuit
- Load sense auxiliary hydraulic circuit
- Planetary reduction at the wheels with sealed wet disc brakes
- Heavy-duty 14,000 lbs (6,350 kg) capacity axles.

STEERING

- Front steer orbitrol, hydrostatic type

SPEEDS

- Travel: 10 mph (16 km/hr)

TIRES & WHEELS

- 10R17.5

OPERATOR STATION

- Left-hand entry into spacious 2 door cab
- Headlight bar with front and rear lights
- Pressurized cab with filtered A/C and heat
- Fully adjustable reclining seat with armrests

BRUSH

- Core size 32" (813 mm) diameter
- Core length 72" (18929 mm)
- 150 RPM

SERVICE CAPACITIES

- Fuel – 67 gallons (253 l)
- Hydraulic tank – 67 gallons (253 l)
- Water tank (optional) – 220 gallons (833 l)

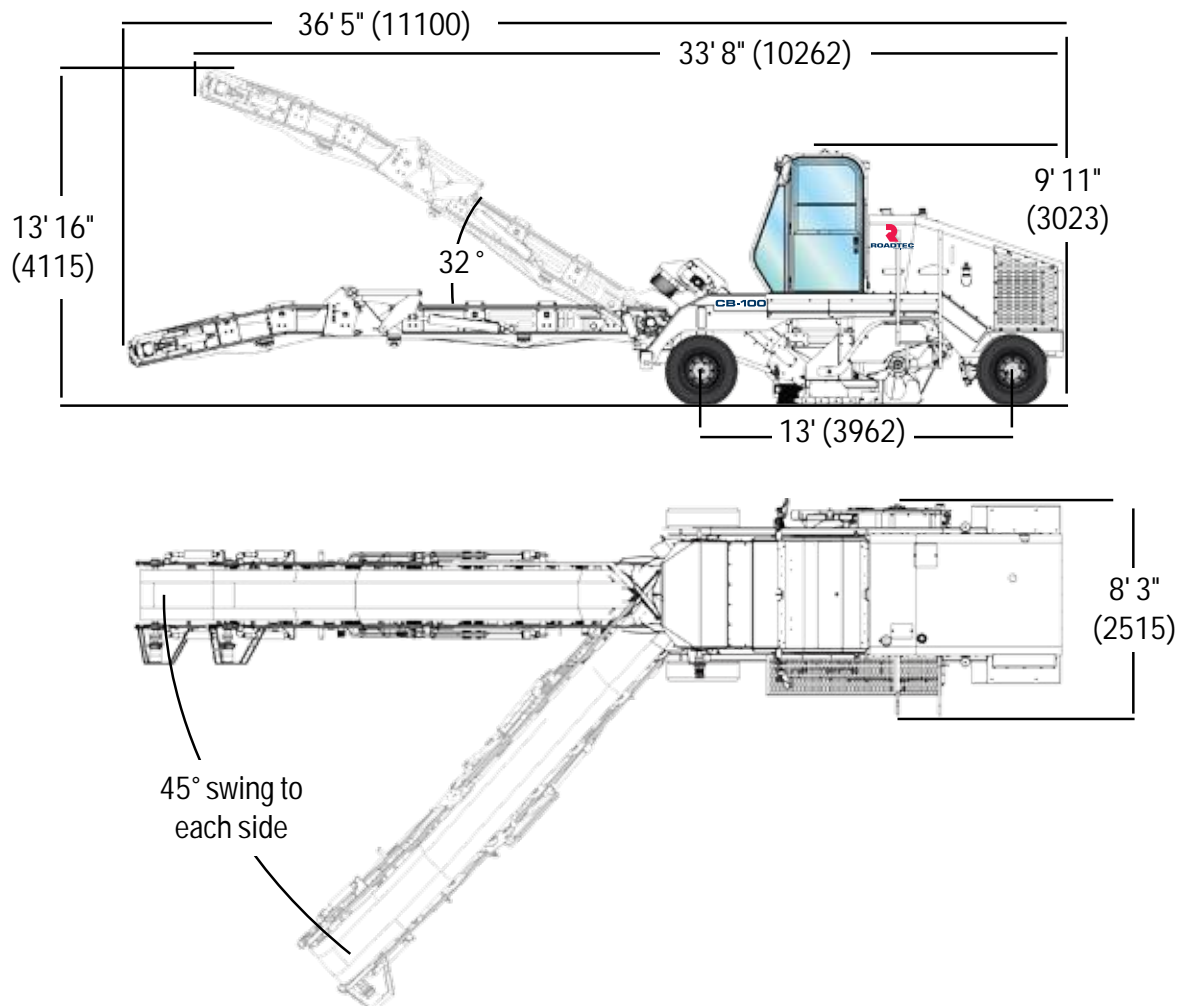

Dimensions in brackets are mm.

Specifications are subject to change without notice.